

Year 10 VCE VET  
Furnishing /  
Engineering

## LAMP Project

Design and  
manufacture



The wooden lamp project is the final design project in Year 9. Students are tasked with integrating an LED lamp system into an original design. The design can be fabricated from timber, metal or both. Students are encouraged to utilise their Design and technology skills to create complex and aesthetically pleasing designs



### Finished Project

Create project  
with a range of  
tools and  
equipment

### Portfolio

Create Design Solution

### Skills Assessment

Create project  
with a range of  
tools

### Toolbox Manufacture

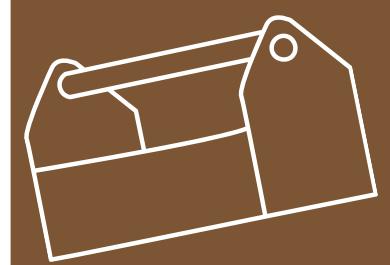

The timber toolbox is another skills assessment where students are introduced to a wider range of woodworking processes and joints. Students also operate a wider range of power tools and plant equipment

### Design Portfolio (Sketches, CAD Drawings)

CAD Modelling  
with OnShape  
Software.  
Creating detailed  
plans  
Toolbox design

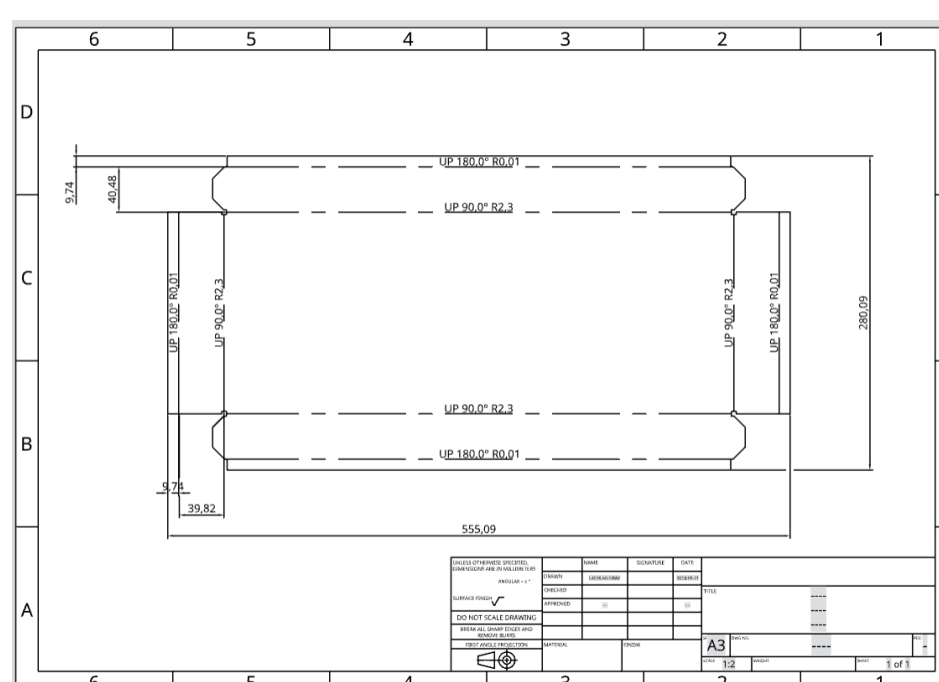

### Safety Quiz

Safety in the  
Workshop, risk  
assessment  
Safety  
Induction

The CO2 Dragster project is the first opportunity the students have to create an original design and model. Students follow the design process to generate a range of different designs, then create and test a prototype.



Year 9

CO2 Racecar  
Design,  
Manufacturing  
and Analysis

Design and  
3D Print with  
OnShape

Design Portfolio  
(Sketches,  
CAD Drawings)

Finished Project

Practical  
Assessment



The pencil box is the first skills assessment, where students for a design brief to construct a functional tool box. This project gives students the opportunity to use a range of hand and power tools



MicroBit  
Controller  
with Metal  
Component

Design,  
Manufacture  
and Programming

### Pencil Box Manufacture

Create project with  
a range of tools and  
equipment

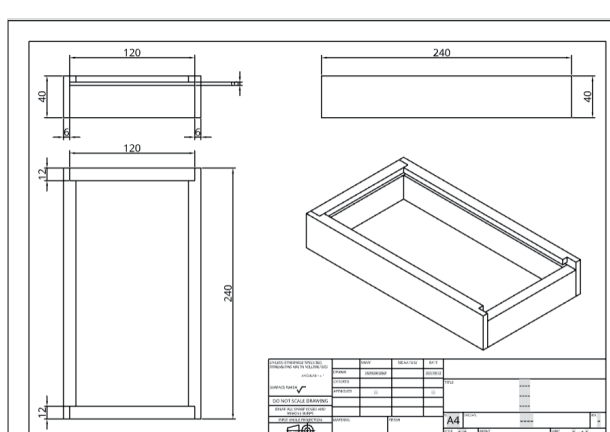

Students in Year 8  
learn to operate  
Computer Aided  
Design software.  
This allows  
students to design  
and modify 2D, and  
3D designs

### Pencil Box Design

CAD Modelling with  
Onshape software.  
Creating detailed  
plans

Safety Induction -  
Safety in the workshop, risk  
assessment

### Safety Quiz

Design Portfolio  
(Sketches,  
CAD Drawing)

Year 8

